

UH195

Plug-on Transmitter

OPERATING INSTRUCTIONS and trouble-shooting guide

LECTROSONICS, INC.

Rio Rancho, NM

INTRODUCTION

Thank you for selecting the Lectrosonics UH195 plug-on transmitter. The UH195 combines over 80 years of engineering experience with the very latest components, in a design that addresses the most demanding professional applications.

The design of the UH195 was the direct result of numerous conversations with users, staging and touring companies and dealers across the US. The specific concerns and needs brought up in these conversations led directly to the development of the operational features offered on the UH195.

The UH195 is a rugged, machined aluminum package. Phantom power is provided on pins 2 and 3. Level indicating LEDs are provided to make level settings quick and accurate, without having to view the receiver. The battery compartment accepts any 9 Volt alkaline battery and makes a positive connection via self-adjusting contacts.

Only the UH195 transmitter is covered in this manual. Companion receivers are covered in separate manuals. The UH195 will operate with any 195 Series Lectrosonics receiver on the same frequency.

TABLE OF CONTENTS

INTRODUCTION	2
GENERAL TECHNICAL DESCRIPTION	3
INSTALLATION	4
FRONT PANEL DESCRIPTION.....	5
REAR PANEL DESCRIPTION	6
OPERATING INSTRUCTIONS	8
REMOTE LEVEL CONNECTIONS	9
TROUBLESHOOTING	9
SERVICE AND REPAIR	10
RETURNING UNITS FOR REPAIR	10
SPECIFICATIONS	11
APPENDIX 1: SERIAL PORT HARDWARE AND SOFTWARE	12
SERIAL PORT COMMANDS AVAILABLE	13
WARRANTY	Back cover

The UH195 transmitter is FCC type accepted under Part 74: 470-608 MHz.

GENERAL TECHNICAL DESCRIPTION

The UH195 transmitter is comprised of a number of functional sub-systems as shown in the block diagram below.

The 195 system uses 75kHz wide deviation. The transmitter circuits are all regulated to allow full output power from the beginning (9 Volts) to the end (7 Volts) of battery life. The oscillator crystal is shock mounted to provide ruggedness. The input amplifier uses a Motorola 33078 op amp for ultra low noise operation. It is gain controlled with a wide range input compressor which cleanly limits input signal peaks over 40dB above full modulation.

The 195 system utilizes an ultrasonic tone modulation of the carrier to operate the receiver squelch. This "pilot tone" consists of a 33kHz signal mixed with the audio signal following the microphone preamp, just after the compandor, to control the audio output muting of the receiver. The pilot tone is filtered out of the audio signal immediately after the detector in the receiver so that it does not influence the compandor or various gain stages. The basic benefit of the pilot tone squelch system is that the receiver will remain muted until it receives the pilot tone from the matching transmitter, even if a strong RF signal is present on the carrier frequency of the system. This is extremely important in applications such as with an automatic sound system.

Traditionally, compandors have been a source of distortion in wireless microphone systems. The basic problem with conventional systems is that the attack and decay times are always a compromise. If the time constants are fast, high frequency transients will not be distorted, but this will cause low frequency distortion. If the time constants are slower, low frequency audio distortion will be low, but high frequency transients will then be distorted. The 195 system introduces an entirely new approach to solving this basic problem, called "dual-band companding."

There are actually two separate compandors in the 195 system, one for high frequencies and one for low frequencies. A crossover network separates the frequency bands at 1kHz with a 6dB per octave slope, followed by separate high and low frequency compandors. The attack and release times in the high frequency compandor are fast enough to keep high frequency transient distortion at a low level, and the low frequency compandor uses slower time constants, reducing low frequency distortion to well below that of a conventional compandor.

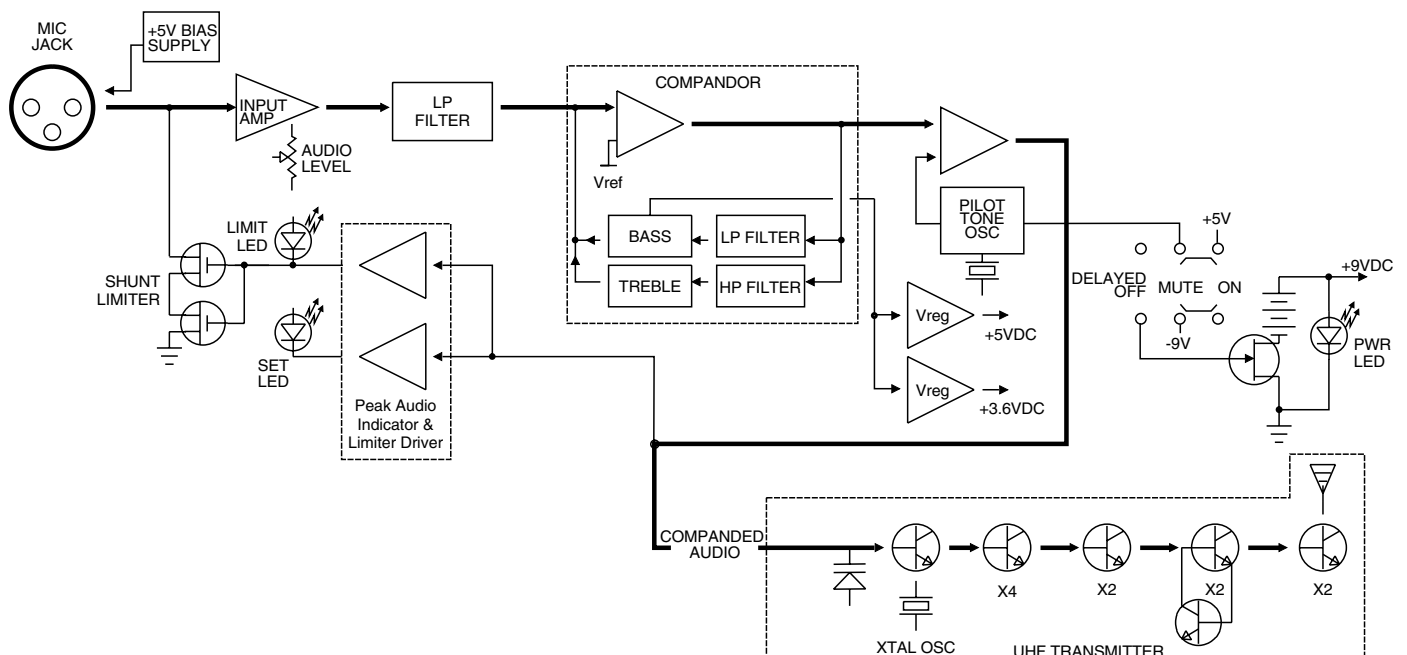

CONTROLS AND FUNCTIONS

The UH195 may be used with a wide variety of microphones. The 3-pin XLR connector on the UH195 allows the transmitter to be used with any dynamic microphone, as well as many two wire positive bias lavalier systems (such as those systems supplied by Lectrosonics).

INPUT JACK

Standard 3-pin Switchcraft XLR type. Pin 2 is signal, pin 3 is signal ground, and pin 1 is case ground (see schematic below). The UH195 is self-locking onto a standard microphone. The XLR connector is permanently bonded to the metal collar, and is not normally replaceable. The electret bias is 5 Volts at 1mA or less. The bias is connected in a “phantom” manner and will not interfere with any standard balanced microphone. If severe noise is experienced when the microphone is moved with respect to the UH195, the cause is an unbalanced condition between pins 2 and 3 of the microphone.

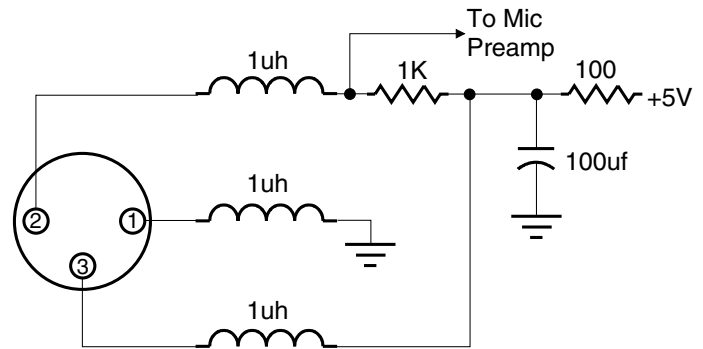

POWER/MUTE SWITCH

Turns the battery power on and off. The center position is an “audio mute” which should be used when setting the MIC LEVEL control. The “mute” position disconnects the audio signal from the transmitter and allows you to adjust the audio modulation level without the possibility of feedback. When turning the transmitter on, pause for a moment in the “mute” position. This will prevent a turn-on surge from occurring (a “thump” sound).

POWER ON/OFF LED

Glow brightly when battery is good. A weak or dim LED means that the battery is weak, and has about an hour of operation left. If the LED fails to light, the battery should be replaced. The power LED should light up in both the “mute” and “on” positions of the POWER/MUTE SWITCH.

The **POWER LED** is connected to a precision battery test circuit that continuously monitors battery voltage. The LED is at full brightness with a new 9 Volt alkaline battery. As the battery voltage drops during use, the LED brightness will also decrease. After 7 to 8 hours the battery voltage will be about 7 Volts. The LED will be completely extinguished. Since the internal circuits are all tightly regulated and the RF output stage has a separate discrete regulator, the transmitter will continue to operate to a battery voltage of 6.5 Volts.

From 6.5 Volts to 6 Volts, the transmitter will still operate, but with degraded performance. Please note that a weak battery will sometimes light the POWER LED immediately after turn on, but soon will discharge to the point where the LED will extinguish.

The combination of an accurate battery condition indicator and regulation of all internal circuits guarantees much longer battery life, as well as consistent performance versus battery life.

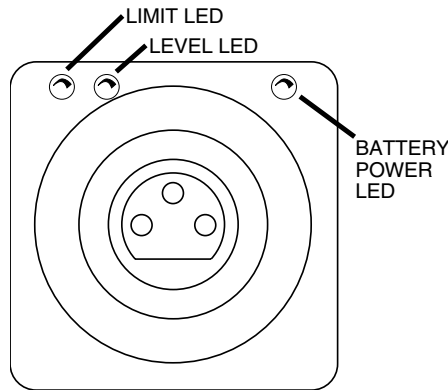

TOP VIEW

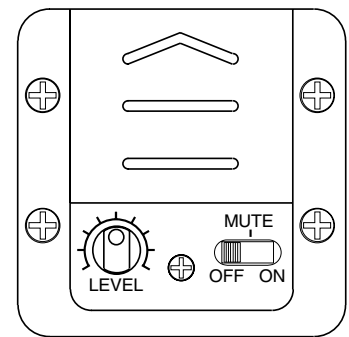

CONTROL PANEL

MODULATION LEDS: Indicate the proper setting of the MIC LEVEL control.

LEVEL LED: Flickers or glows all the time if the audio volume is adequate for normal operation.

LIMIT LED: Lights up when the audio volume is high, indicating that the signal level is being limited by the compressor. Optimum signal-to-noise ratio is obtained when the limit LED lights occasionally.

MIC LEVEL: Used to adjust the audio input volume for the proper modulation level. Rotate knob until the LEVEL LED flickers when there is an input signal. The LIMIT LED should light occasionally.

OPERATING INSTRUCTIONS

1) Insert the UH195 into the selected microphone. Listen for the “click” that indicates the UH195 has locked on to the microphone. Pull on the mic to insure proper locking has occurred.

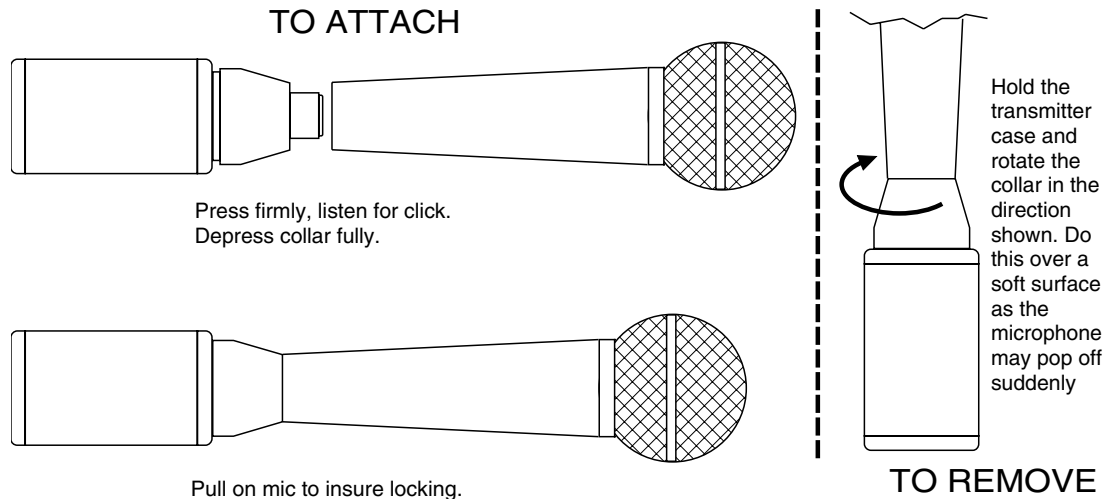

2) Turn the power switch to the “MUTE” position on both the transmitter and the receiver. The “MUTE” position allows internal voltages to stabilize before audio signal paths are opened.

3) Hold the microphone as you will when you will be using it.

4) Speak as loudly as you expect to speak in normal system use. Rotate the MIC LEVEL knob so that the LEVEL LED flickers or stays lit as you speak. The LIMIT LED should light up on loud “peaks.” *Occasional lighting of the LIMIT LED (about 10-15% of the time) indicates proper operation and optimum signal-to-noise ratio.* Even when the transmitter is limiting, little distortion is produced because of the high linearity of the gain control circuit.

5) Move switches to “ON” position on both the transmitter and the receiver and adjust the level of the sound system or recorder.

NOTE:

The MIC LEVEL control should not be used to control the volume of your sound system or level of your recorder. This is accomplished using the level control on the receiver, on the mixing console, or recorder.

If the mic level is too high - the LIMIT LED will light frequently or stay on. This condition may cause distortion.

If the mic level is too low - neither LED will light, or the LEVEL LED will light dimly. This condition will cause hiss and noise. You may experience severe reduction in apparent range if the modulation level is too low. It may sound as if you are getting dropouts. What is actually happening is that you are hitting your noise floor because the S/N ratio has been compromised by the low modulation.

The LEVEL LED turns on at -12dB below full deviation. The LIMIT LED turns on at full deviation and indicates that the input shunt compressor is operating. The input compressor operates over a full 30dB range regardless of the gain control setting. The compressor uses a true absolute value circuit to detect both positive and negative peaks. The attack time is 2 milliseconds and the release time is 80 milliseconds. Occasional limiting is desirable, indicating that the gain is correctly set and the transmitter is fully modulated.

BATTERY REPLACEMENT

The UH195 transmitter is powered by a standard alkaline 9 Volt battery. It is important that you use **ONLY ALKALINE** batteries for longest life. Standard zinc-carbon batteries marked "heavy duty" or "long-lasting" are not adequate. They will provide only about 3 hours of operation. Similarly, nicad rechargeable batteries only give 3 hours of operation, and will also run down quite abruptly. Alkaline batteries provide about 7 hours of operation.

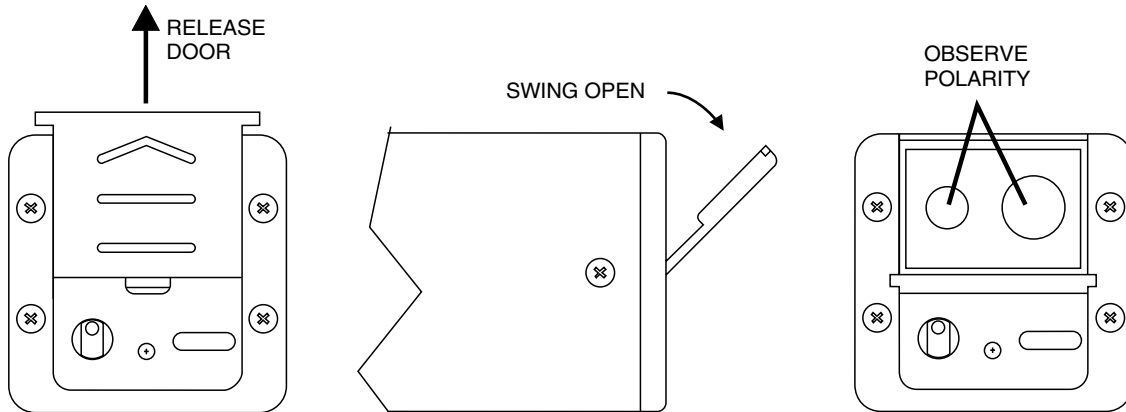

To open the battery compartment, press outward on the cover door in the direction of the arrow as shown in the drawing. Only slight, sliding pressure is needed to open and close the battery door.

Swing the door open and take note of the polarity marked inside showing the location of the positive (+) and negative (-) terminals. Insert the battery and close the cover by pressing in and across, reversing the opening procedure outlined above. Note that the battery door will **NOT** close if the battery is inserted incorrectly, since the terminals will hit a protective polarity barrier.

TROUBLESHOOTING

Before going through the following chart, be sure that you have a good battery in the transmitter the red power LED on the transmitter panel should glow brightly.

SYMPTOM	POSSIBLE CAUSE
<p>NO AUDIO IS HEARD BUT RECEIVER RF LED IS ON</p> <p><i>NOTE: If the modulation level LEDs on the receiver are indicating properly, the problem is NOT in the transmitter.</i></p>	<ol style="list-style-type: none"> 1) On/Off switch is in “mute” position on receiver or transmitter. 2) Microphone on/off switch is in “off” position. 3) Volume is turned down or off on transmitter or receiver. 4) Receiver not properly connected to other audio equipment. 5) Transmitter POWER switch may be turned on and off (i.e. through the mute position). A “thump” should be heard in the sound, again indicating a properly functioning receiver.
<p>NO SOUND IS HEARD AND RECEIVER RF LED IS OFF</p>	<ol style="list-style-type: none"> 1) Transmitter not turned on. Check for power LED. 2) Receiver antenna may be defective or disconnected. 3) Transmitter and receiver frequencies don’t match. Check frequency labels.
<p>NOISE (HISS) IS HEARD ALONG WITH THE SIGNAL</p>	<ol style="list-style-type: none"> 1) MIC LEVEL is too low (see page 5). 2) Transmitter and receiver may be too far from one another. 3) Receiver antenna may be defective or disconnected.
<p>DISTORTED SOUND</p>	<ol style="list-style-type: none"> 1) MIC LEVEL is too high (see page 5). 2) Mic may be distorting; try a different mic and listen again. 3) PA system may be overloading.
<p>EXCESSIVE FEEDBACK</p>	<ol style="list-style-type: none"> 1) MIC LEVEL may be set too high (see page 5). 2) Sound system volume set too high. 3) Microphone too far from the user’s mouth. 4) Loudspeakers may be too close to the mic.

SPECIFICATIONS AND FEATURES

Operating frequencies:	470 to 608 MHz
RF Power output:	100 mW (nominal)
Frequency stability:	± 0.004%
Deviation:	± 75 kHz (max)
Spurious radiation:	50 dB below carrier
Equivalent input noise:	-126 dBV
Pilot tone:	32.768 kHz (± 2Hz); 5kHz deviation
Input level:	Nominal 2 mV to 300 mV, before limiting. Greater than 3 Volts maximum, with limiting.
Input compressor:	Soft compressor, >40 dB range
Gain control range:	43 dB; semi-log rotary control
Modulation indicators:	Dual LEDs indicate modulation level 12 dB below limiting and at the onset of limiting.
Controls:	3 position "OFF-MUTE-ON" slide switch for noiseless turn on/turn off operation. Control panel knob adjusts audio gain.
Battery:	Precision compartment auto-adjusts to accept any known alkaline 9 Volt battery. (We've tried 108 different ones!)
Battery Life:	7.5 Hours with alkaline 9 Volt
Weight:	7 ozs. including battery
Dimensions:	1.5 x 1.5 x 4.2 inches
Emission Designator:	75KOF3E

Specifications subject to change without notice.

SERVICE AND REPAIR

If your system malfunctions, you should attempt to correct or isolate the trouble before concluding that the equipment needs repair. Make sure you have followed the setup procedure and operating instructions. Check out the interconnecting cords and then go through the TROUBLE SHOOTING section in the manual

We strongly recommend that you **do not** try to repair the equipment yourself and **do not** have the local repair shop attempt anything other than the simplest repair. If the repair is more complicated than a broken wire or loose connection, send the unit to the factory for repair and service. Don't attempt to adjust any controls inside the units. Once set at the factory, the various controls and trimmers do not drift with age or vibration and never require readjustment. **There are no adjustments inside that will make a malfunctioning unit start working.**

LECTROSONICS' service department is equipped and staffed to quickly repair your equipment. In warranty repairs are made at no charge in accordance with the terms of the warranty. Out of warranty repairs are charged at a modest flat rate plus parts and shipping. Since it takes almost as much time and effort to determine what is wrong as it does to make the repair, there is a charge for an exact quotation. We will be happy to quote approximate charges by phone for out of warranty repairs.

RETURNING UNITS FOR REPAIR

You will save yourself time and trouble if you will follow the steps below:

A. DO NOT return equipment to the factory for repair without first contacting us by letter or by phone. We need to know the nature of the problem, the model number and the serial number of the equipment. We also need a phone number where you can be reached 8 am to 4 pm (Mountain Standard Time).

B. After receiving your request, we will issue you a return authorization number (R.A.). This number will help speed your repair through our receiving and repair departments. The return authorization number must be clearly shown on the outside of the shipping container.

C. Pack the equipment carefully and ship to us, shipping costs prepaid. If necessary, we can provide you with the proper packing materials. UPS is usually the best way to ship the units. Heavy units should be "double-boxed" for safe transport.

D. We also strongly recommend that you insure the equipment, since we cannot be responsible for loss of or damage to equipment that you ship. Of course, we insure the equipment when we ship it back to you.

Mailing address:

Lectrosonics, Inc.
PO Box 15900
Rio Rancho, NM 87174
USA

Shipping address:

Lectrosonics, Inc.
581 Laser Rd.
Rio Rancho, NM 87124
USA

Telephones:

Regular: (505) 892-4501
Toll Free (800) 821-1121
FAX: (505) 892-6243

World Wide Web: <http://www.lectrosonics.com>

Email: sales@lectrosonics.com

LIMITED ONE YEAR WARRANTY

The equipment is warranted for one year from date of purchase against defects in materials or workmanship provided it was purchased from an authorized dealer. This warranty does not cover equipment which has been abused or damaged by careless handling or shipping. This warranty does not apply to used or demonstrator equipment.

Should any defect develop, Lectrosonics, Inc. will, at our option, repair or replace any defective parts without charge for either parts or labor. If Lectrosonics, Inc. cannot correct the defect in your equipment, it will be replaced at no charge with a similar new item. Lectrosonics, Inc. will pay for the cost of returning your equipment to you.

This warranty applies only to items returned to Lectrosonics, Inc. or an authorized dealer, shipping costs prepaid, within one year from the date of purchase.

This Limited Warranty is governed by the laws of the State of New Mexico. It states the entire liability of Lectrosonics Inc. and the entire remedy of the purchaser for any breach of warranty as outlined above. NEITHER LECTROSONICS, INC. NOR ANYONE INVOLVED IN THE PRODUCTION OR DELIVERY OF THE EQUIPMENT SHALL BE LIABLE FOR ANY INDIRECT, SPECIAL, PUNITIVE, CONSEQUENTIAL, OR INCIDENTAL DAMAGES ARISING OUT OF THE USE OR INABILITY TO USE THIS EQUIPMENT EVEN IF LECTROSONICS, INC. HAS BEEN ADVISED OF THE POSSIBILITY OF SUCH DAMAGES. IN NO EVENT SHALL THE LIABILITY OF LECTROSONICS, INC. EXCEED THE PURCHASE PRICE OF ANY DEFECTIVE EQUIPMENT.

This warranty gives you specific legal rights. You may have additional legal rights which vary from state to state.

LECTROSONICS, INC.

581 LASER ROAD
RIO RANCHO, NM 87124 USA

November 1, 2001